

HDBaseT™ 8×8 HDMI Matrix over CAT5e/6/7

**Operation Manual
VER:1.0**

Thank you for purchasing this product. For optimum performance and safety, please read the instruction carefully before connecting, operating or adjusting this product. Please keep the manual for future reference.

Caution

The extender using UTP cable termination follows the standard of IEEE-568B.

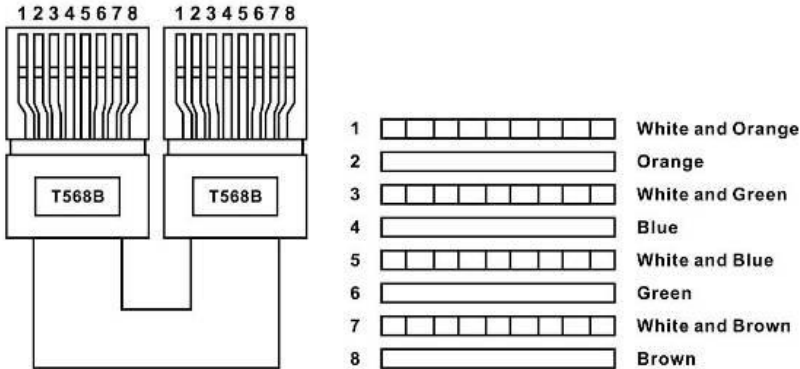

Direct interconnection method

Advanced:

The extender will in Automatic protection mode when using UTP cable termination follows the standard of IEEE-568A.

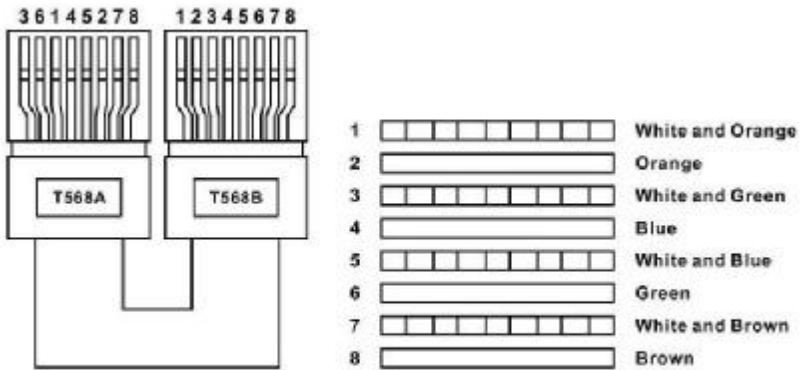

Cross interconnection method

1. Introduction

The HDBaseT 8x8 HDMI Matrix with simultaneous CAT5e/6/7 and HDMI outputs connects eight HDMI sources to sixteen displays. This matrix features eight HDMI outputs and each HDMI eight is mirrored to provide a CAT-Cable output which runs simultaneously. It supports the transmission of video (resolutions up to 1080p Full HD and 4Kx2K@30Hz) and supports high resolution digital audio formats such as LPCM 7.1CH, Dolby TrueHD, Dolby Digital Plus and DTS-HD Master Audio. Connect a HDBaseT Receiver to each of the CAT-Cable outputs to extend the HDMI signal up to 328ft/100m (100m Version) or 230ft/70m(70m version)for multi-room connectivity. It works with Blu-Ray players, Set-Top boxes, Home Theater PCs, and game consoles that connect to an HDMI display. Any source is accessible at all times by any display by selecting it via the supplied IR Remote Control, RS-232, TCP/IP or by using the selection buttons on the front panel. This device supports High Definition Audio, and 3D signal compatibility.

2. Features

- HDMI input supports: HDMI2.0, HDCP 2.2 and DVI1.0 compliant
- Supports HDMI 3D pass-through
- Supports resolutions from VGA~WUXGA and HD resolutions from 480i~1080p~4Kx2K@30 dependent upon the EDID settings
- Supports transmission distances up to 328ft/100m (100m Version) or 230ft/70m(70m version) through CAT5e/6/7 cable
- Support POE function
- Supports simultaneous HDMI and CAT outputs
- Supports wideband IR(30-60Khz) matrix system, IR transport channel can be forward or backward. And supports GLOBAL IR input and output.
- Supports RS-232, remote control, on-panel control and TCP/IP Control
- Supports smart EDID management
- Supports Digital Audio and stereo audio outputs

- Support bi-directional IR& RS232 control
- Supports HDBaseT LAN Serving function
- Supports LPCM 7.1CH, Dolby TrueHD, Dolby Digital Plus and DTS-HD Master Audio transmission

3.Package Contents

- HDBaseT 8x8 HDMI Matrix----- 1PCS
- HDBaseT Receiver----- 8PCS
- AC power cable----- 1PCS
- Operation Manual-----1PCS
- Wideband IR Tx cable-----9PCS
- Wideband IR Rx cable-----10PCS
- HDMI Matrix IR Remote----- 1PCS
- Mounting ears(Matrix)-----2PCS
- Mounting ears(Receiver)----- 16PCS
- RS232 cable----- 1PCS

4.Specifications

Video Bandwidth	297MHz[10.2Gbps]
Support Video Resolution	480i,576i,480p,576p,720p,1080i,1080p24/30/50/60,4Kx2K@30;
Input Ports	8×HDMI, 10×IR Receiver, 1×RS-232, 1×RJ-45(Control),8×Rs232
Output Ports	8×CAT5e/6/7, 9×IR Blaster, 8×HDMI 8×Audio,8×Digital audio
HDMI connector	Type A 19 pin female
RJ-45 connector	WE/SS 8P8C
3.5mm connector	(TX and RX) IR Receiver/IR Blaster
ESD Protection	Human-body Model: ± 8kV (Air-gap discharge) ± 4kV (Contact discharge)
Power Supply	AC 100~240V 50/60Hz
Dimensions Dim	440 mm (W)×362 mm (D)×88 mm (H)

Weight	1820 g
Chassis Material	Metal
Silkscreen Color	Black
Operating Temperature	0 °C~40 °C/32 °F~104 °F
Storage Temperature	-20 °C~60 °C/-4 °F~140 °F
Relative Humidity	20~90 % RH (non-condensing)
Power Consumption	100 W(max)/0.5w(Standby)

5. PANEL FUNCTIONS

5.1 Front Panel

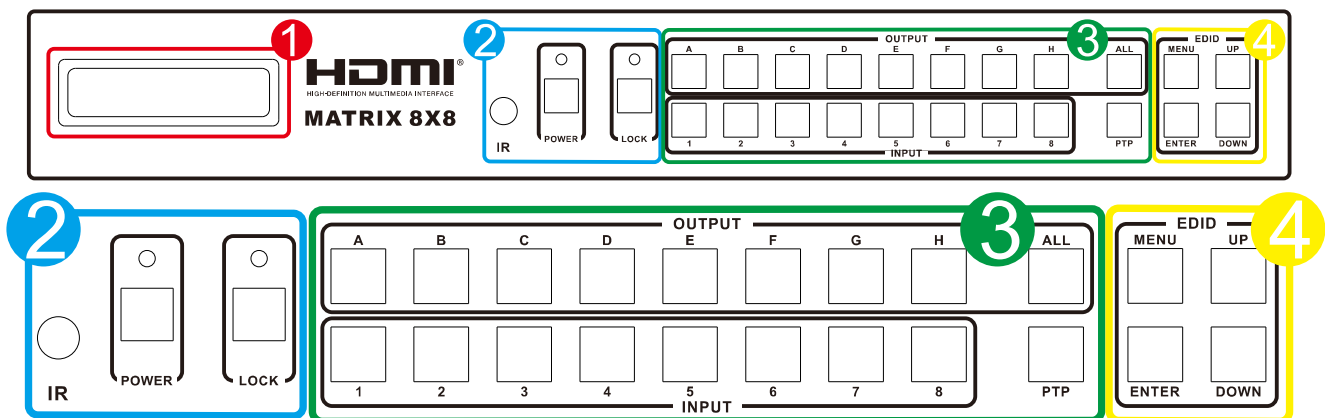

- 1. LCM:** Displays the information of each input and output setting and EDID management
- 2. IR:** IR Receiver window (accepts the remote control signal of this device only).
POWER: Press this button to power the device on/off. The LED will illuminate green when the power is on, red when it is in 'Standby' mode.
LOCK: Press this button to lock all the buttons on the panel, press again to unlock.
- 3. OUTPUT/INPUT:** Press the OUTPUT and INPUT button to select the output corresponding input.
For example: Press OUPUT ALL>INPUT 1, The OUTPUT A/B/C/D/E/F/G/H will be set to INPUT 1.
Press PTP button, The OUTPUT A/B/C/D/E/F/G/H will corresponding INPUT 1/2/3/4/5/6/7/8.

4. EDID: Smart EDID management, the LCM will display the EDID operation.

Press the MENU button will enter the EDID management window, press UP or DOWN button to select the needed EDID setting, press ENTER button to select the download input source. It can easy download any EDID mode to any input source.

Note: The EDID mode table

EDID Mode	EDID Description
1	1080i, 2CH AUDIO
2	1080i, DOLBY/DTS 5.1
3	1080i, HD AUDIO
4	1080p, 2CH AUDIO
5	1080p, DOLBY/DTS 5.1
6	1080p, HD AUDIO
7	3D,1080p, 2CH AUDIO
8	3D, 1080p,DOLBY/DTS 5.1
9	3D,1080p, HD AUDIO
10	4kx2k, 2CH AUDIO
11	4kx2k, DOLBY/DTS 5.1
12	4kx2k, HD AUDIO
13	DVI 1024x768
14	DVI 1920X1080
15	DVI 1920X1200
16	Copy from HDMI OUTPUT A
17	Copy from HDMI OUTPUT B
18	Copy from HDMI OUTPUT C
19	Copy from HDMI OUTPUT D
20	Copy from HDBT OUTPUT A
21	Copy from HDBT OUTPUT B
22	Copy from HDBT OUTPUT C
23	Copy from HDBT OUTPUT D

EDID. What is it and what is it used for?

Under normal circumstances, a source device (digital and analog) will require information about a connected device/display to assess what resolutions and features are available. The source can then cater its output to send only resolutions and features that are compatible with the attached device/display. This information is called EDID (Extended Display Information Data)

and a source device can only accept and read one EDID from a connected device/display. Likewise, the source can only output one resolution for use by a connected device/display.

Why is EDID so important with the HDMI Matrix ?

The Matrix is complex piece of technology that replicates and switches between multiple inputs and outputs. Each connected source device will require one EDID to read. EDID management is carefully handled by HDMI Matrix to provide a single EDID for each source to read.

What options do I have to manage the EDID in the HDMI Matrix ?

First, it is important to note that each source device can only output one video/audio signal type. This includes resolutions and timings. When multiple devices/displays are used, such as with the HDMI Matrix, it is important to use devices/displays that have similar or compatible resolutions/features. This will ensure that the single video/audio signal produced by the source device is accepted by all of the connected output devices/displays. The user has the option, through the EDID management window, to choose how the unit will manage the EDID from multiple HDMI devices/displays. Therefore the user has some control over the resolutions/features that the source devices will output. The HDMI Matrix has a multiple EDID management modes that will control how the EDID information from multiple devices/displays are combined, ignored, and routed.

5.2 Rear Panel

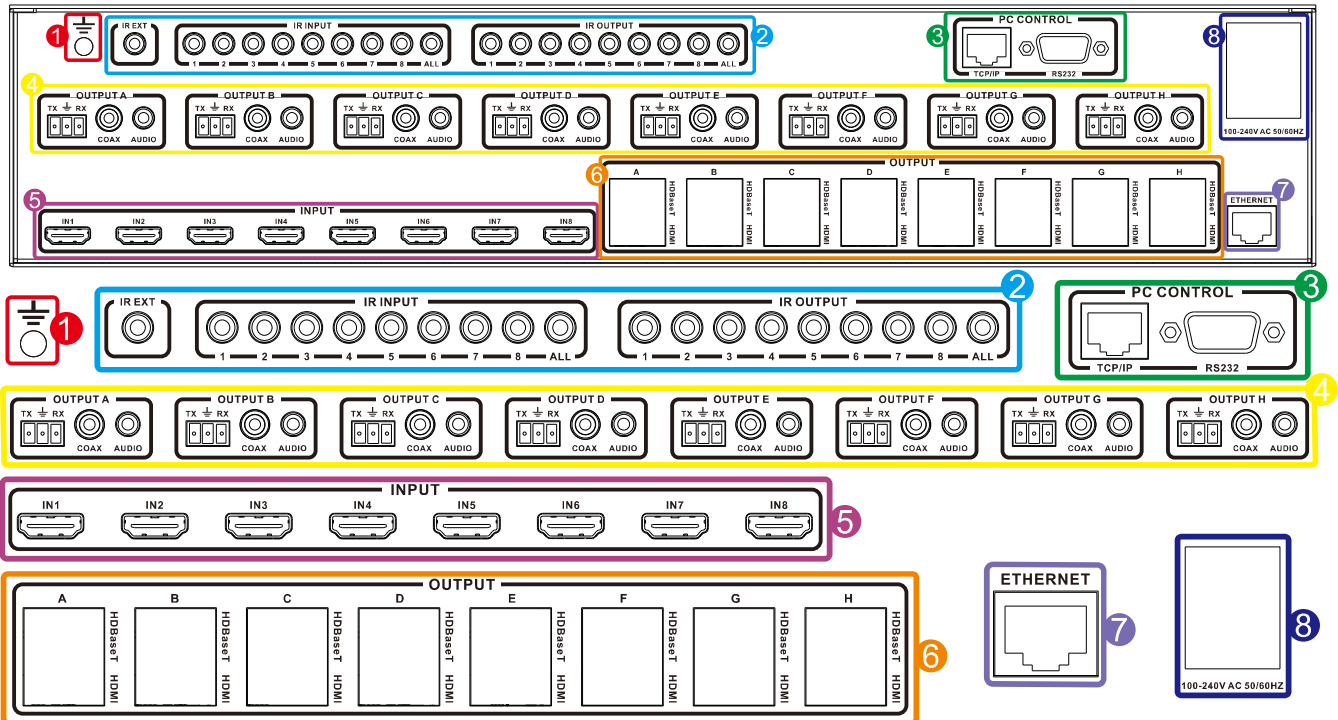

1. GND: Connect the Housing to ground.

2. IR Matrix

IR EXT: if the panel sensor is obstructed or the unit is installed in a closed area out of infrared line of sight, the IR RX receiver included can be inserted into the IR EXT port at the rear to extend the IR sensor range and enable local control of the matrix.

IR IN/OUT: Super IR control system interface. For further details, please refer to the Super IR system control introduction.

3. PC CONTROL

TCP/IP: This port is the link for TCP/IP control, connect to an active Ethernet link with an RJ45 terminated cable.

RS232: Connect to a PC or control system with D-Sub 9-pin cable for the transmission of RS-232 commands.

4. AUDIO OUTPUT: The coaxial and analog audio output connects to the audio amplifier. The TX and RX for RS232 communication with the HDBT Receiver TX and RX.

5. HDMI INPUT: Connect to the HDMI input source devices such as a DVD player or a Set-top Box with HDMI cable.

- 6. VIDEO OUTPUT:** The HDMI OUTPUT connect to HDMI equipped TVs or monitors and the HDBT OUTPUT connect to the HDBT Receiver.
- 7. Ethernet:** This slot provides Internet signal from receiver or to receiver.
- 8. AC POWER INPUT:** Connect to AC power with AC power cable.

6. Remote Control

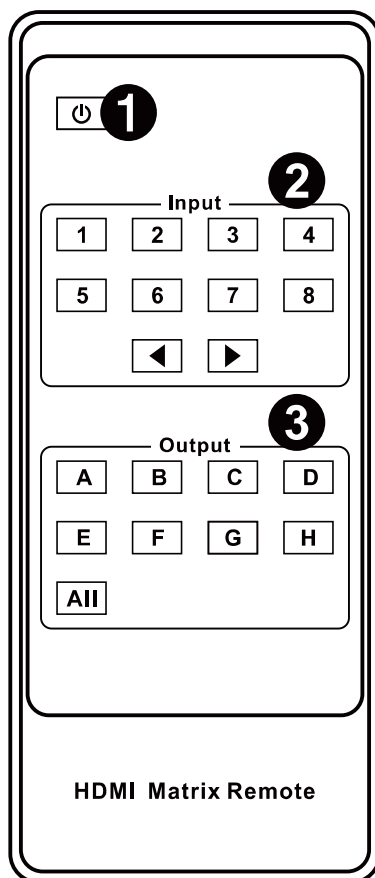

- 1. Power on /Standby:** Press this button for power on the matrix or set it to standby mode.
- 2. Input port selection area:** Press these buttons to select input 1-8. Press forward/backward button will cycle from input 1-8.
- 3. Output port selection area:** Press these buttons to select output A-H, including ALL.

How to operate the Matrix Remote?

- Power on and standby
- Q.** How to power on and standby?
A. Press Power on /Standby button and wait a while.
- How to select Output and Input Port?
- Q.** OUTPUT-X select INPUT-Y:
A. Press OUTPUT-X (X means 1 to 8 of outputs, including ALL)
Press INPUT-Y (Y means 1 to 8 of inputs)

7. IR Control system (IR Call-back of Matrix and Source Devices)

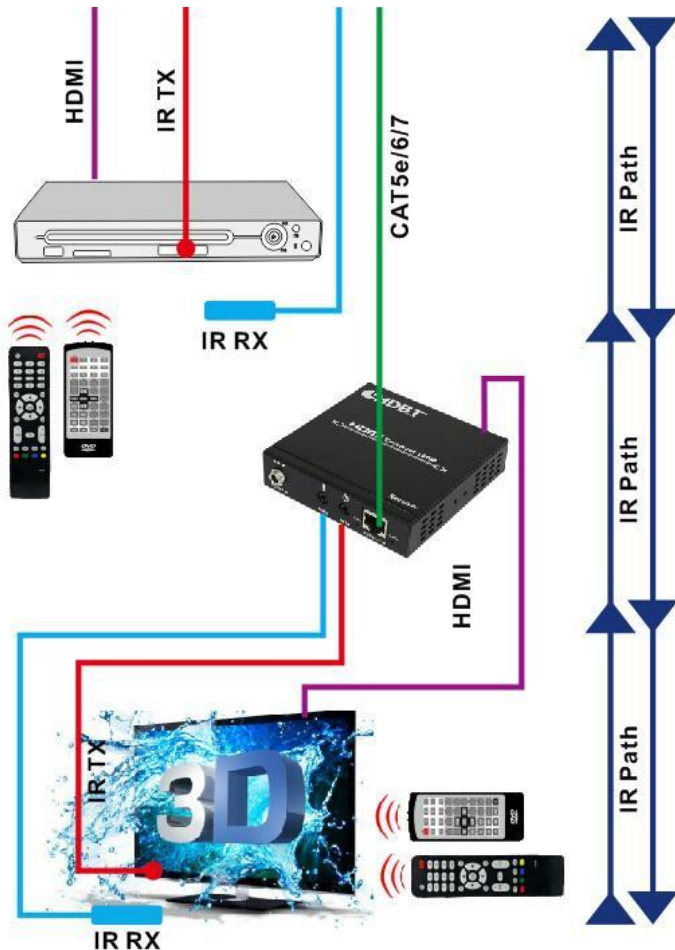
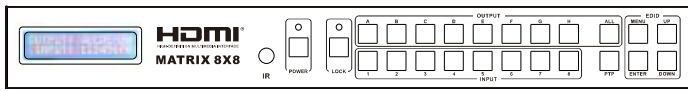

The matrix is not only a switcher and extender of multiple HDMI signals to multiple HDMI receivers located remotely, it also passes IR control signals through the IR call-back system to the matrix and HDMI sources for full, independent control of all connected inputs from output locations.

Two-way IR Call-back Between matrix, Sources and Displays from Multiple Locations

A key feature on the matrix is discrete IR control of the matrix, sources and displays from any location – so inputs at the matrix end can be controlled at a display location

and displays can be controlled at the matrix location. This is accomplished by placing a series of IR Emitters on devices to control and IR Receivers at all locations you wish to control from to enable the IR signal to travel both ways via the single Cat5e/6/7 cable.



01. At Matrix end: Insert the 3.5mm jacks of the IR TX Emitters included with the unit into the IR TX Emitter ports at the rear of the matrix according to input. The IR signal is added to the HDMI of the input device so, for example, if the user is watching Blu-ray on input 1,

the IR signal will be directed through the IR TX1 socket to control the device.

As each IR TX port is allocated to an individual HDMI input port, if the user is unable to establish IR control of the device, care should be taken to check firstly, that the IR emitter and HDMI input ports match (Input 1-TX1, Input2-TX2 etc.) with plugs secured in correct ports, and secondly, that the IR TX emitter sensors are firmly attached directly to the front of inputs and covering infrared sensor windows of the source devices. Some later adjustment may be needed to the location of the sensor to achieve the best performance results - sometimes moving the sensor to different areas on the source can improve IR performance.

NOTE: Infrared receiving areas of devices can be located by shining a flashlight onto the front of the device – the sensor should be able to be seen through the plastic as a small, round object inside. Insert 3.5mm jacks of IR RX receivers into RX ports, making sure the receivers themselves are placed in clear view to receive an infrared signal from the remote handset used to control the display outputs.

02. At display end: Insert the IR RX Receiver jack into the IR RX port of the display receiver balun, with the receivers themselves placed in clear view on or near the displays to receive an infrared signal from the remote handset used to control inputs. Insert the IR TX Emitter jack into the IR TX port of the display receiver balun, ensuring that the emitter sensor is securely attached to infrared sensor window of the display. Follow the same connection and positioning for all baluns/displays connected to the matrix. If all IR TX Emitters and IR RX Receivers are positioned and connected correctly with sources, displays and display receivers fully powered and the matrix set to IR call-back enabled and IR TX Switch mode activated, two-way IR will now be possible.

Note: Misplaced or poorly secured IR Emitters and Receivers may result in intermittent IR control signals passed to and from the matrix. Check your placement and adjust if necessary.

IR RECEIVER



IR BLASTER

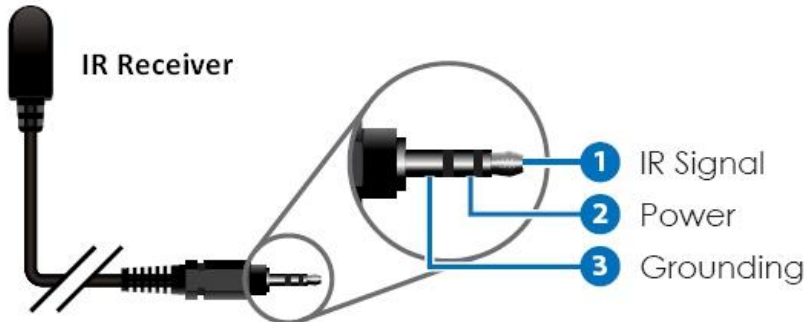
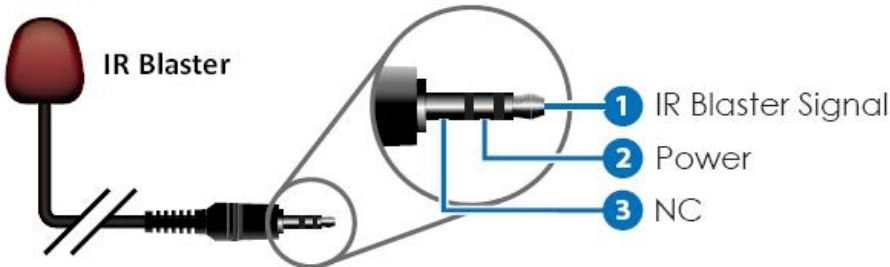

8. HDBT Receiver

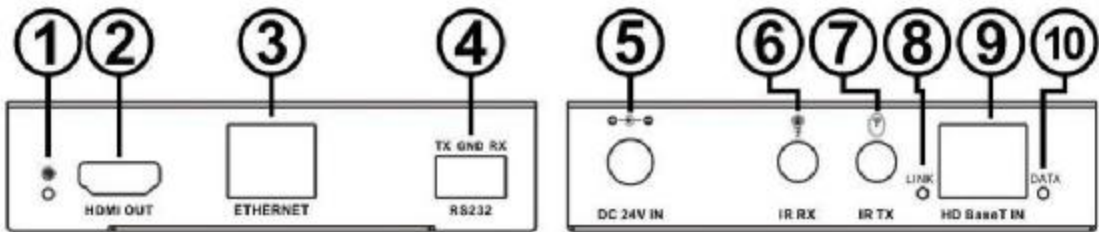

1. OUTPUT LED: The output status indicating lamp. This red LED illuminates when the TV plugs in with HDMI cable.

2. **HDMI OUT:** HDMI output port. This slot is where you connect the HDTV or monitor with HDMI cable.
3. **ETHERNET:** This slot provides Internet signal from transmitter or to transmitter.
4. **RS232:** Phoenix jack provides Serial port control signal from transmitter or to transmitter.
5. **DC IN:** Plug the 24V DC power supply into the unit.
6. **IR RX:** Chanel 2 IR Receiver. Connect with Wideband IR Rx.
7. **IR TX:** Chanel 1 IR Transmitter. Connect with Wideband IR Tx.
8. **LINK LED:** The connection status indicating lamp.
 - ※Illuminate: The Transmitter and Receiver are in good connections
 - ※Flashing: The Transmitter and Receiver are in poor connections
 - ※Dark: The Transmitter and Receiver are in no connections
9. **HDBaseT IN:** Standard HDBaseT signal input port. Connect HDBaseT transmitter with a UTP cable following the standard of IEEE-568A or IEEE-568B.
10. **DATA LED:** The data status indicating lamp.
 - ※Illuminate: The HDMI signal with HDCP.
 - ※Flashing: The HDMI signal without HDCP.
 - ※Dark: No HDMI signal.

9. PC controller user guide

Installation

Matrix controller is a green software. Just copy MatrixController.exe to PC which is used to control the Matrix by RS232 COM port or TCP/IP to complete installation.

Preparation

- Connect PC and Matrix by RS232 cable (headers of both sides of cable should be FEMALE) or TCP/IP(local area network)
- Power-up Matrix
- Double click MatirxController.exe icon to run it

How to control Matrix

“General” page

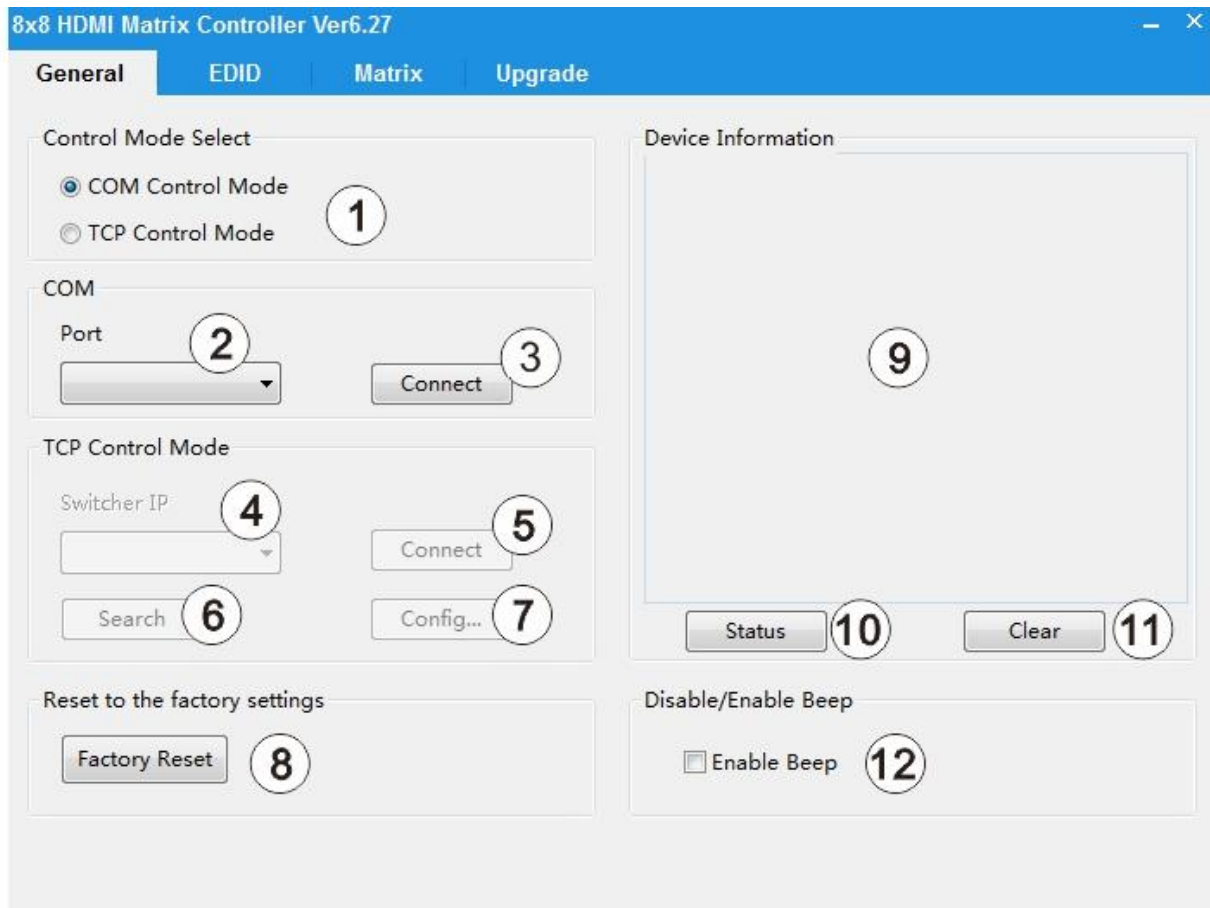

1. Select RS232 COM or TCP mode
2. Select RS232 COM port
3. Click to connect or disconnect PC and Matrix
4. Select Matrix IP
5. Connect to Matrix IP
6. Search Matrix IP
7. Configure Matrix IP and MAC
8. Click to reset to the factory settings
9. Device information display area
10. Click to refresh device status: include device information displayed in 9 area and Input/Output Settings on “Matrix” page
11. Click to clear device information
12. Enable or disable Beep

Configure TCP

After action of 7 , edit form will pop-up as below:

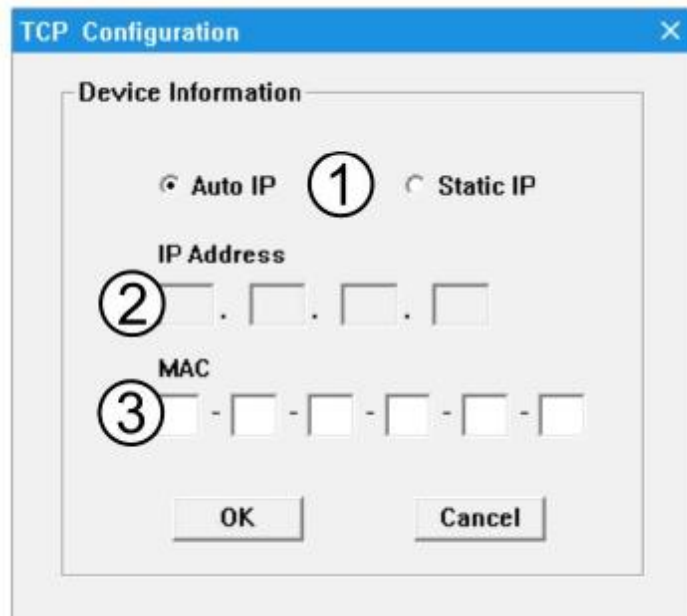

1. Select auto or static IP
 2. Rewrite the Matrix IP
 3. Rewrite the Matrix MAC
- “EDID control” page**

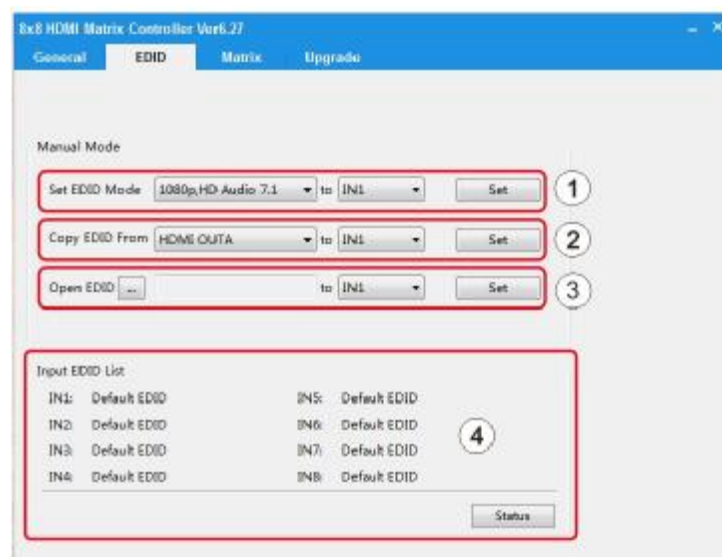

The controller have 3 methods to set the EDID mode. Manual mode, Copy mode and open EDID file mode.

1. Select the needed EDID to input port and click set button the EDID will write to the selected HDMI input ports.

2. Copy the selected HDMI output or HDBT output EDID and click set button to write to the selected HDMI input ports.
3. Open the user define EDID file and click set button to write to the selected HDMI input ports.
4. Click the status button to refresh input EDID status.

“Matrix” page

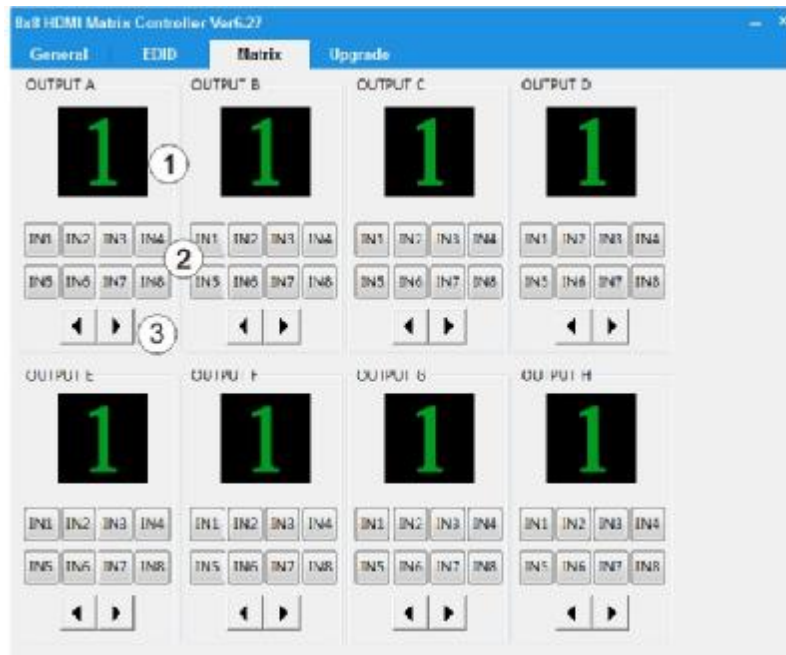

1. LED which display Input number for respective Output
2. Click to select Input port for respective Output port
3. Click to select previous or next Input port for respective Output port

“FW upgrade” page

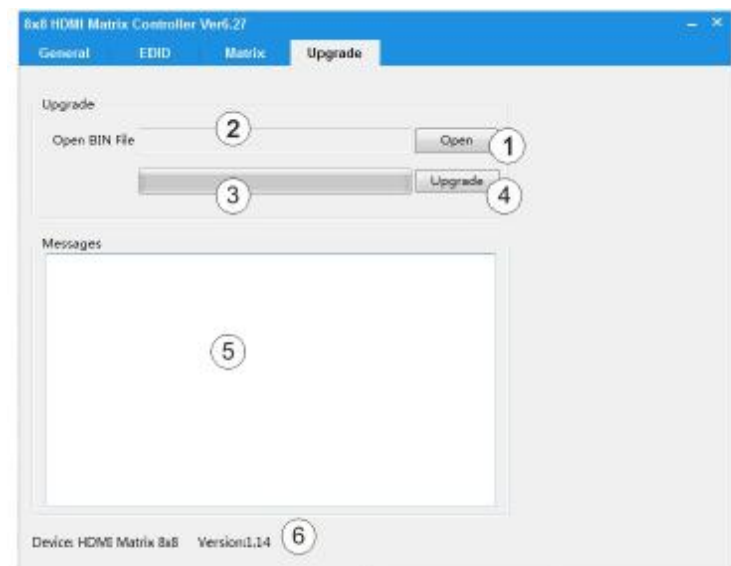

1. Click to open FW file(file extension is “.fw”)
2. Display the FW file path
3. Displaying the progress of the software upgrade
4. Click to upgrade the Matrix software
5. Display the message of the software upgrade
6. When the PC communication with matrix normal, you can see the matrix firmware version

10. Operate and Connect

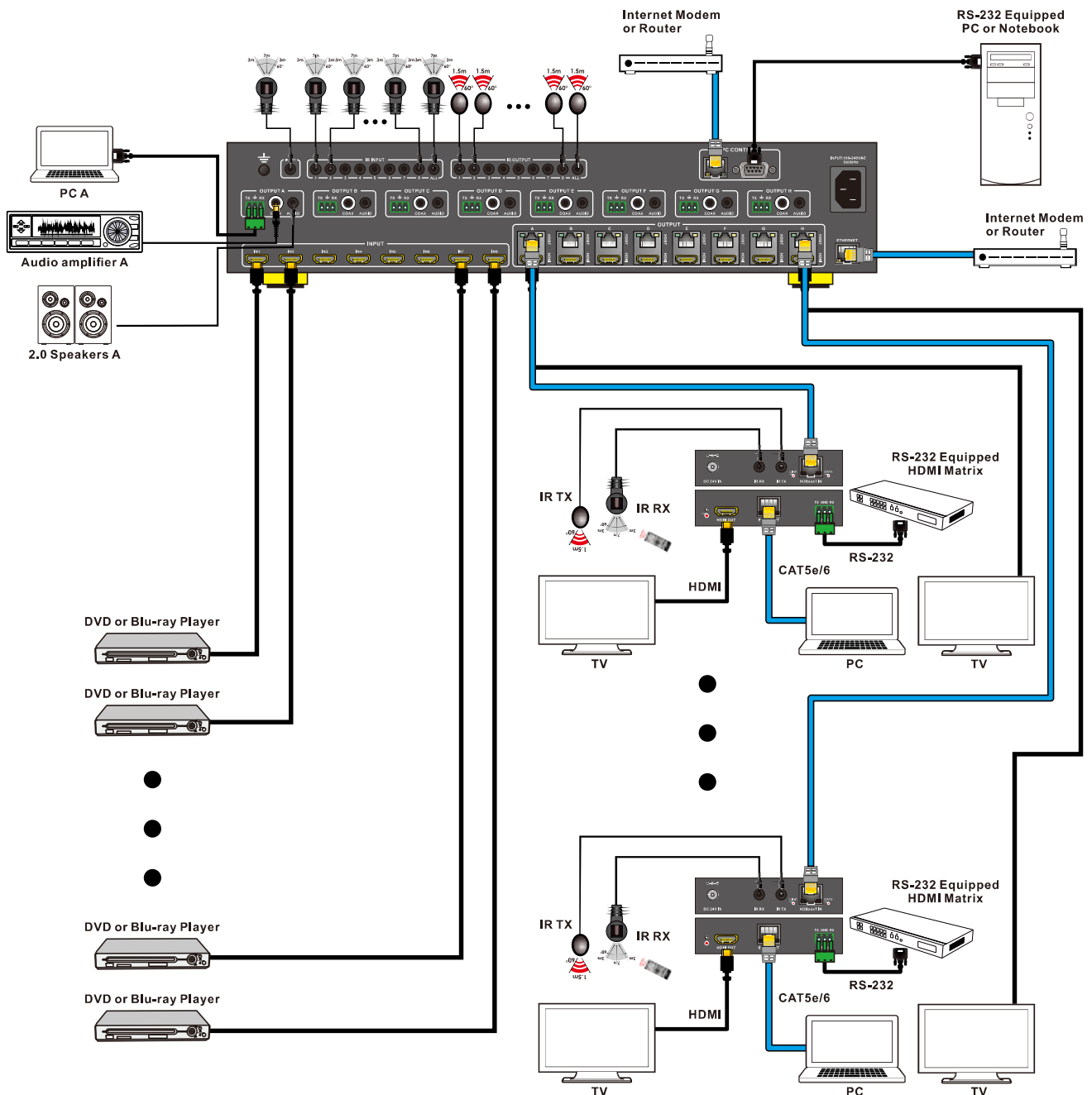

1. Connect up to 8 sources such as a Blu-Ray Player, game console, A/V Receiver, Cable or Satellite Receiver, etc. to the HDMI inputs on the unit. Do not hotplug! Insert and extract cables carefully with the power switch off. Connecting and disconnecting while the unit is powered can result in damage to circuitry.
2. Connect the output HDBT ports and/or HDMI output ports, starting with output 1, to the HDBT Receiver display receivers (sold separately) (using well terminated or pre-terminated Cat5e/6/7 cables no longer than 328 ft)
3. If utilizing UTP, connect the output HDMI ports of the HDBT Receiver display receivers (sold separately) to high-definition displays such as an HDTV or HD projector that use HDMI inputs. Note that high-speed HDMI cables are recommended for the distances that are required for each connection.
4. Plug in IR transmitters to the back of the Matrix Selector Switcher unit (IR TX), the transmitters are labeled IR TX, place in front of the IR receiver of the source, ensure that each emitter is placed in front of the IR receiver eye. Double-sided adhesive tape provided.
5. Plug in IR receivers to the port of the HDBT Receiver display receivers (sold separately) ,the receivers are labeled IR RX, use provided double-sided adhesive tape to stick emitters at each display at a desired place that will receive a remote signal.
6. For power, plug in the source first, followed by the Matrix (power supply included), followed by the display receivers, followed by each output connected.
7. Power on each device in the same sequence.

Supports power over cable function

This system can run by only the matrix(TX) is powered, RXs do not need powered.

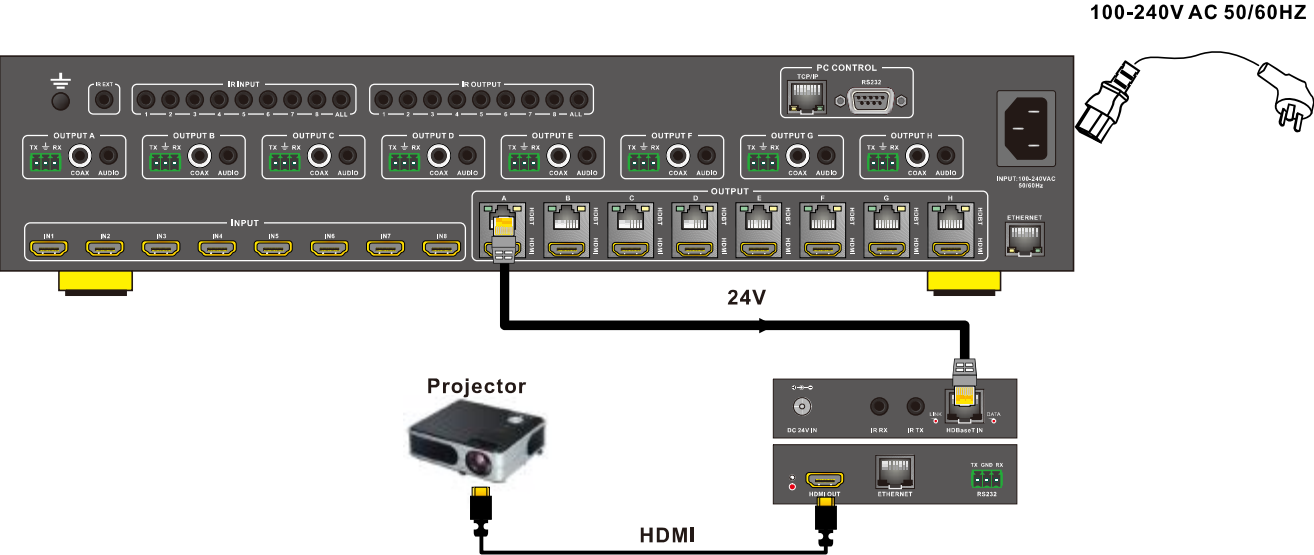

Supports Bidirectional RS232 control function

This system provides 8 channels RS232 pass through functions, Can be controlled through these channels you want to control the equipment. For example 1, the PC or control system sends RS-232 signals control projector.

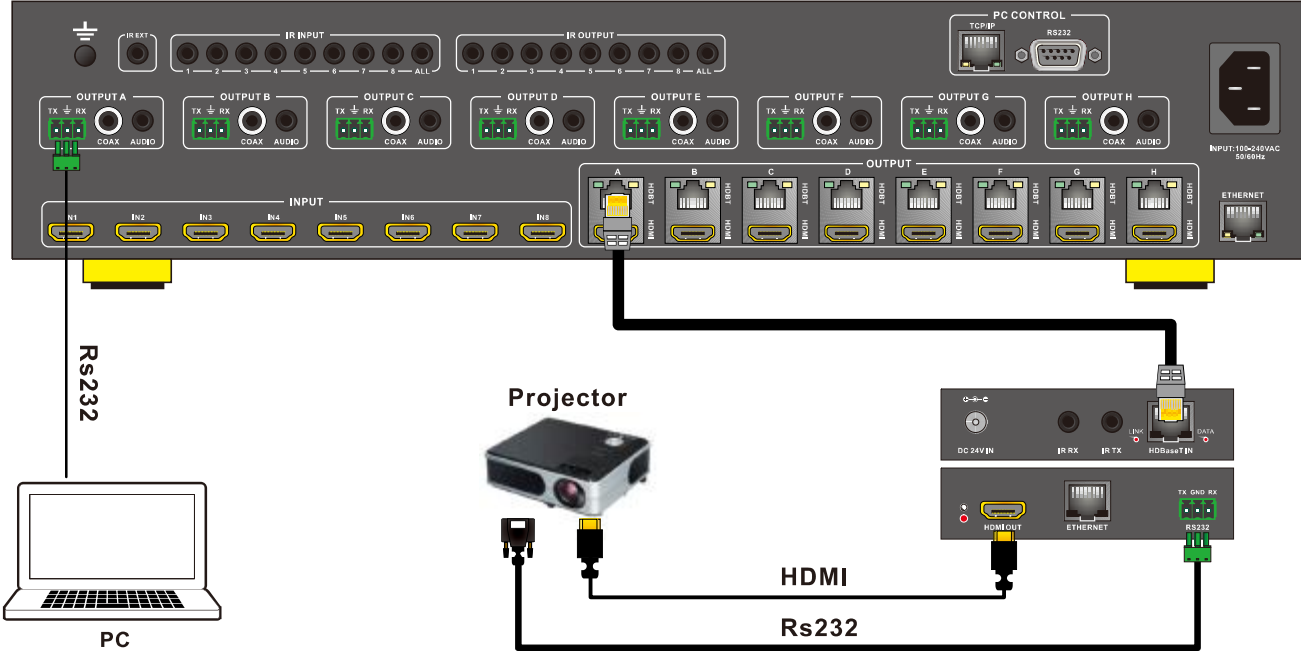

User Manual

For example 2, the PC or control system sends RS-232 signals control HDMI Matrix

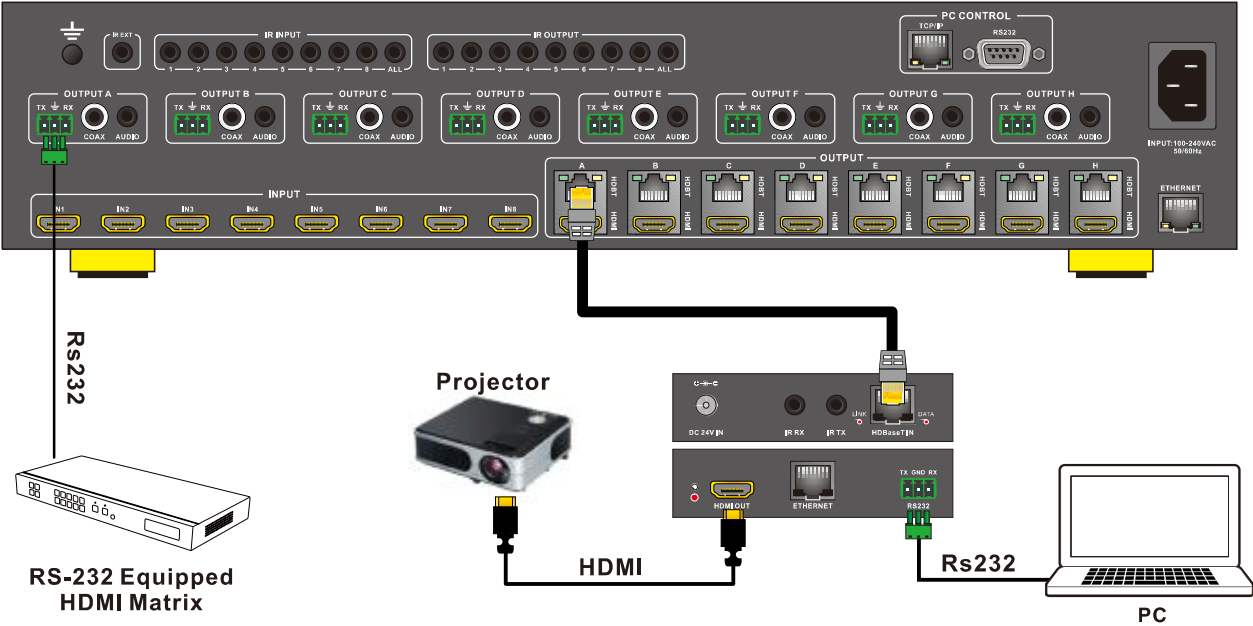

Supports GLOBAL IR function

Use IR All input port can control all TV at the same time.

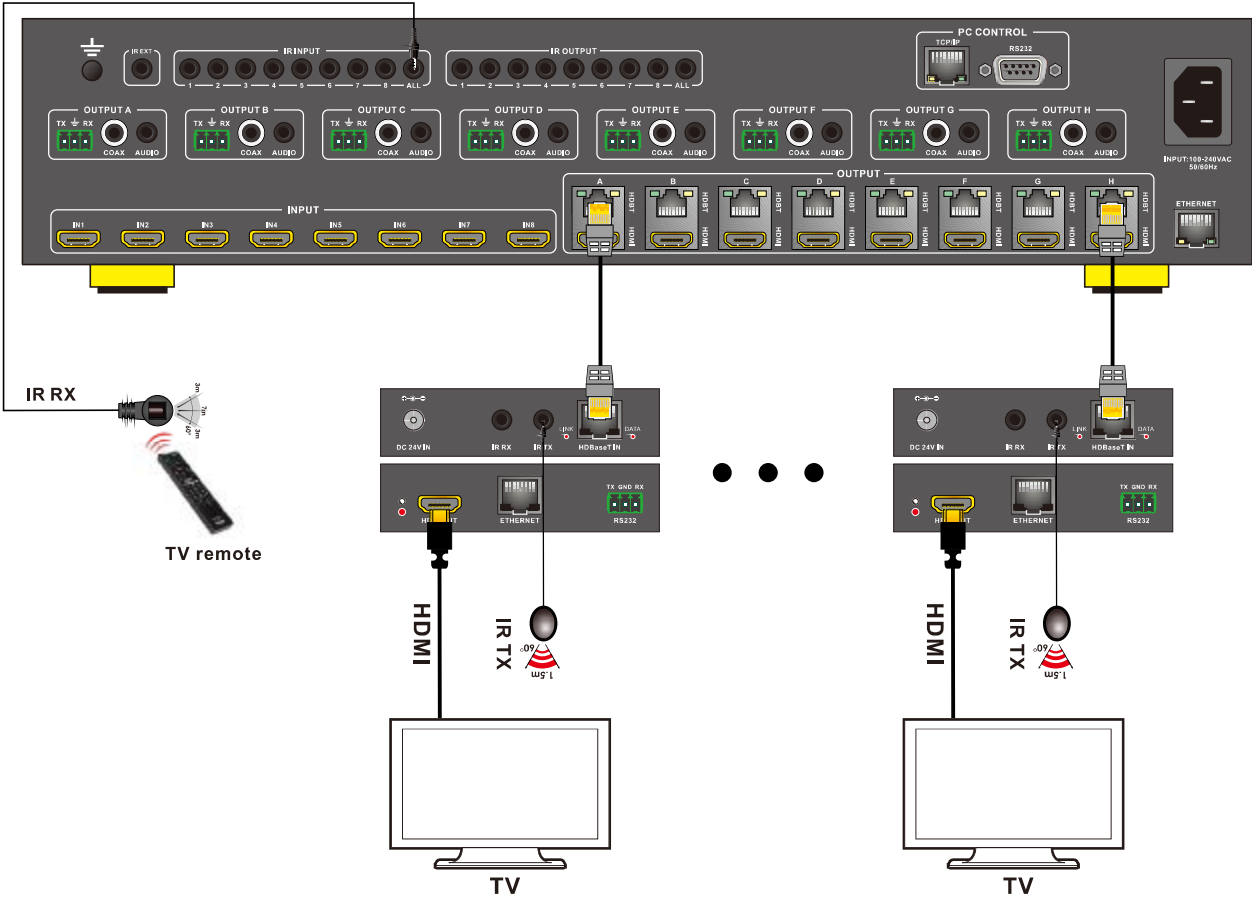

The IR Blaster (IR TX) connect to the IR All output port, At the far end can use DVD Remote control DVD, but not at the same time.

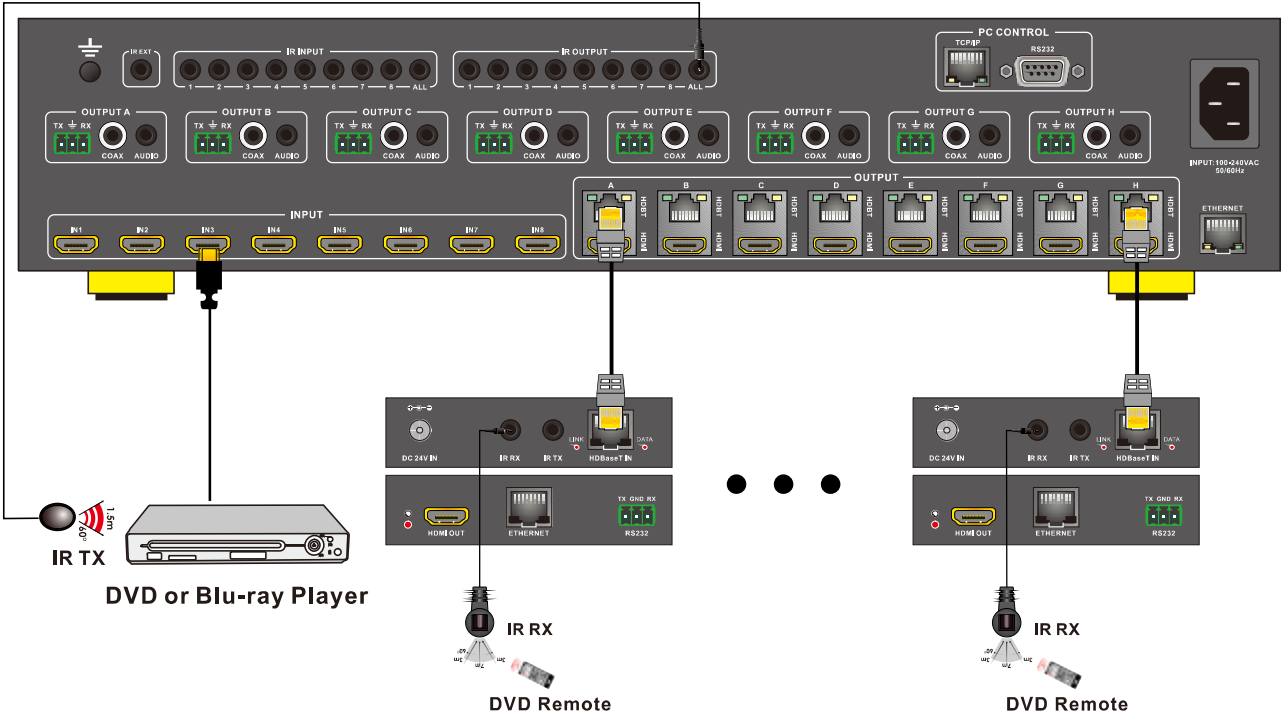

Supports HDBaseT LAN Serving function

The matrix has an Ethernet port, the port with the 8 Receiver Ethernet ports formed into a local area network (LAN).

